

ORACLE®

Building a Better User Experience with Oracle User Experience Design Patterns

Richard Davis
Oracle Australia Pty Ltd
HCM Solutions Consultant

March 2013



Safe Harbor

The following is intended to outline our general product direction. It is intended for information purposes only, and may not be incorporated into any contract. It is not a commitment to deliver any material, code, or functionality, and should not be relied upon in making purchasing decisions. The development, release, and timing of any features or functionality described for Oracle's products remains at the sole discretion of Oracle.

UX Comes To Life, Without Thinking!

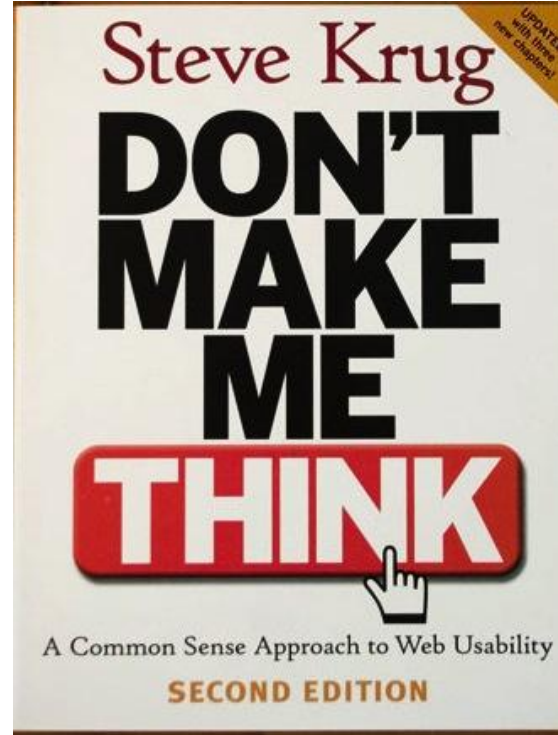
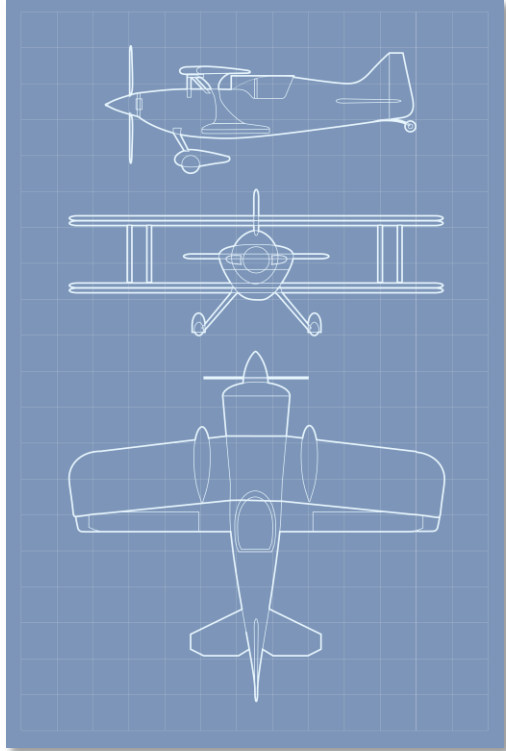

UX Design Patterns 101: Everyday Tasks, Easy

Global area pattern

Breadcrumbs navigation

Contextual action

Ratings

Global area pattern: The top navigation bar of the iTunes Store, containing links for Music, Films, App Store, Books, Podcasts, and iTunes U.

Breadcrumbs navigation: The path 'Music > Rock > U2' located below the navigation bar.

Contextual action: A menu of actions including 'Gift This Album', 'Add to Wish List', 'Tell a Friend', 'Copy Link', 'Share on Facebook', and 'Share on Twitter' that appears over the album cover.

Ratings: The 'iTunes Ratings and Reviews' section, which displays an average rating of 4.5 stars based on 24 ratings and includes a 'CLICK TO RATE' button.

UX Design Patterns 101: Mobile Tasks

Heat map analytics

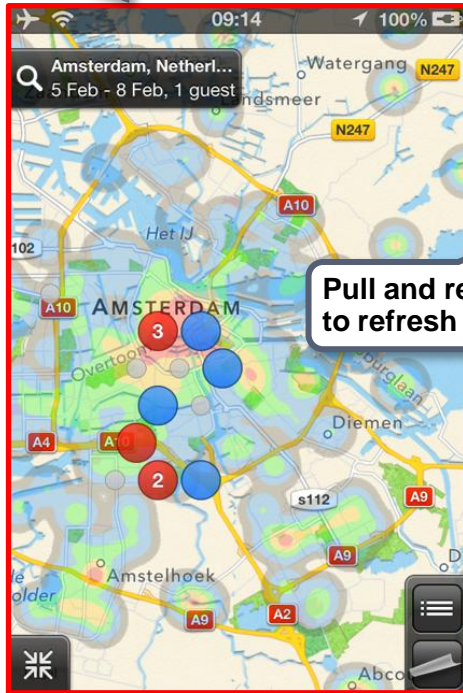

Pull and release to refresh

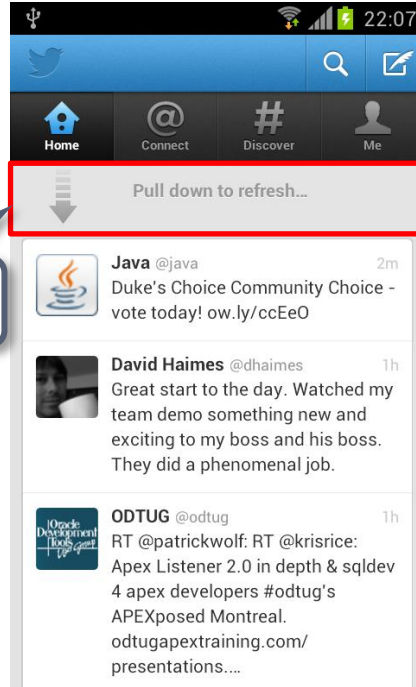

Pull and release to create

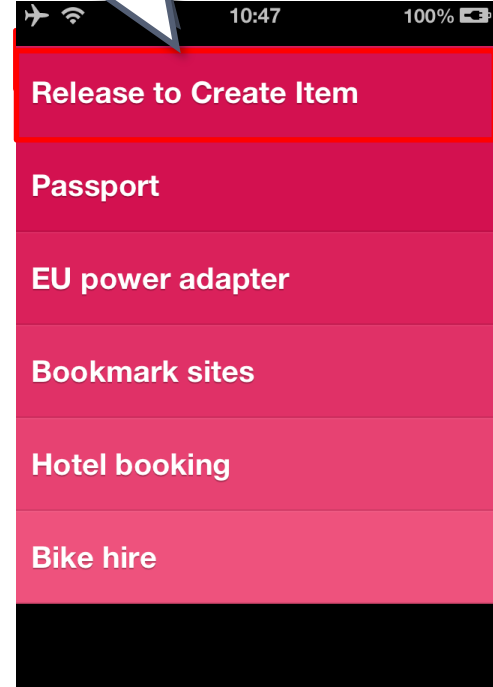

Oracle User Experience Design Patterns

- Oracle process and use of applications UX design patterns
- Pattern benefits for all
- Patterns strategy for applications



UX Design Patterns: Applications Consistency

- Reusable common solutions
- Scientifically proven
- Oracle Fusion Middleware
- Developer productivity
- User satisfaction
- Business benefits

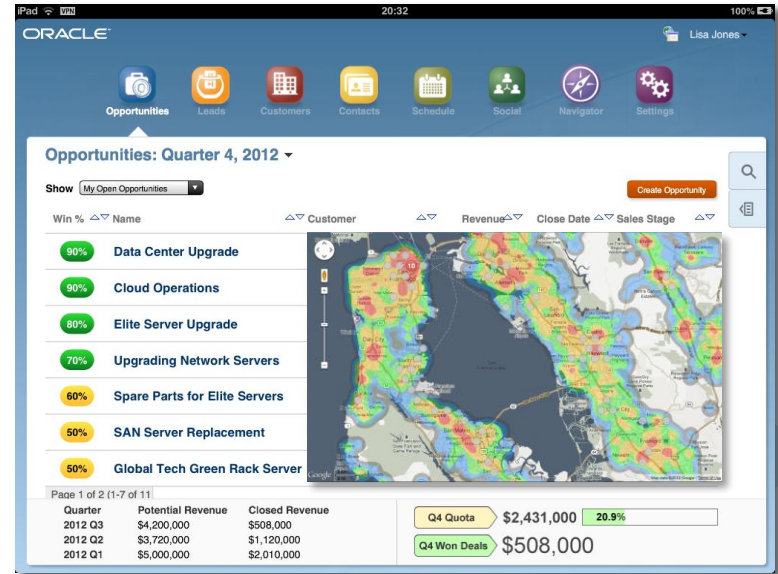

What are Design Patterns?

- Reusable user experience solutions to common problems or tasks in enterprise software

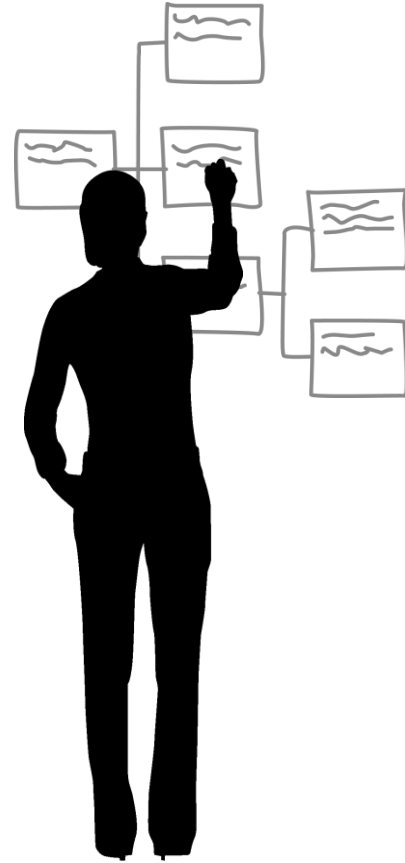

Applying Design Patterns

To Both Current and Future Applications Products

- New products are designed with patterns
- Additions to existing products use patterns as starting point, modify to fit product
- Goal: Customer or partner extensions can use patterns as part of a UX process to be consistent with future products





User Interface vs. User Experience



User Experience

The complete experience for a user around accomplishing a task, including across traditional applications boundaries.

UX Design Patterns: Oracle Process

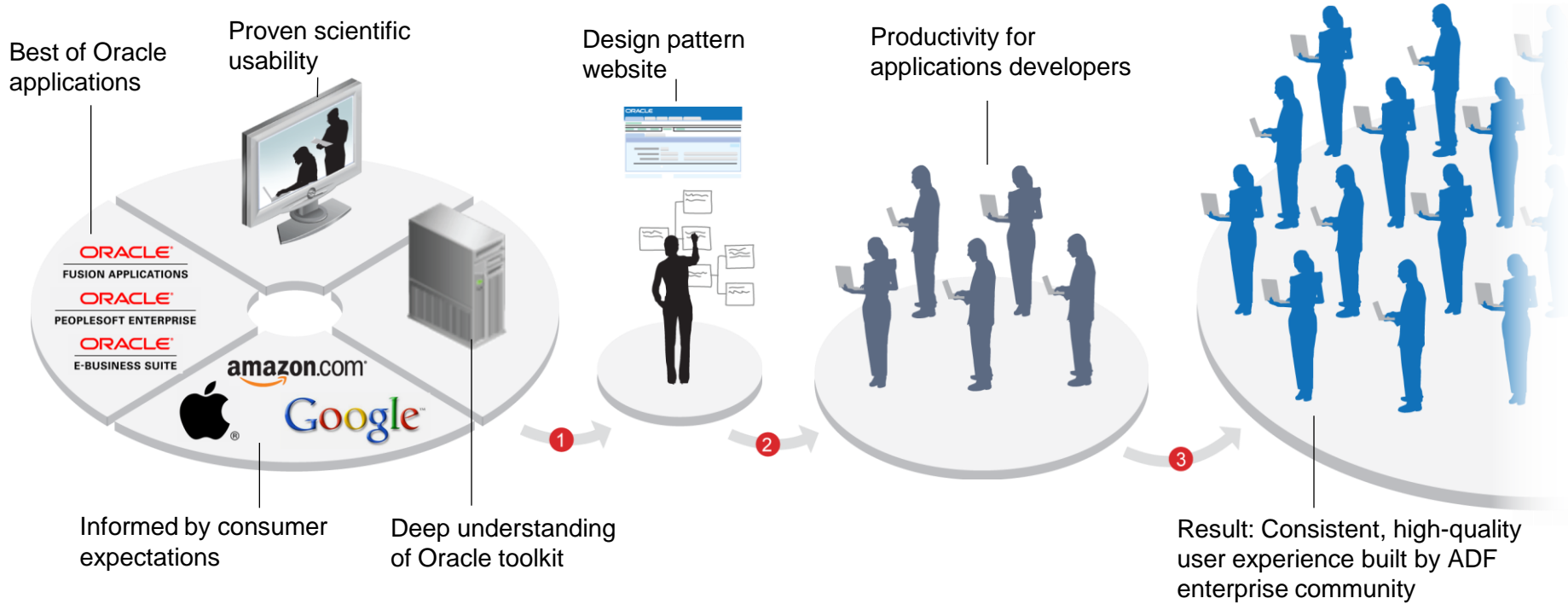

UX Design Patterns: Oracle Fusion Applications

Out of the Box Usability Applied by Developers

The screenshot displays the 'Journal Lines' interface in Oracle Fusion Applications. At the top, there is a title bar with a dropdown arrow and a help icon. Below it is a toolbar with 'Actions', 'View', and 'Format' menus, followed by icons for adding (+), deleting (X), copying, and pasting, and buttons for 'Detach' and 'Wrap'. The main area contains a table with columns for 'Line', 'Account', and 'Entered (USD)' (subdivided into 'Debit' and 'Credit'). A tooltip is open over the account field of line 1, showing a hierarchical breakdown of the account number 3111-000-0000-0000-40110-1111-0000.

Line	Account	Entered (USD)	
		Debit	Credit
1	3111-000-0000-0000-40110-1111-0000		8,500.00
		8,500.00	
		8,500.00	8,500.00

Segment	Value	Description
Company	3111	Vision Foods Marketing - US
Cost_Center	000	None
Program	0000	None
Location	0000	None
Account	40110	White Wine Revenue
Division	1111	New York
Product	0000	None
Intercompany	0000	None

Common UX Design Patterns

Persistent Global Area High-Level Actions Streamlines Navigation

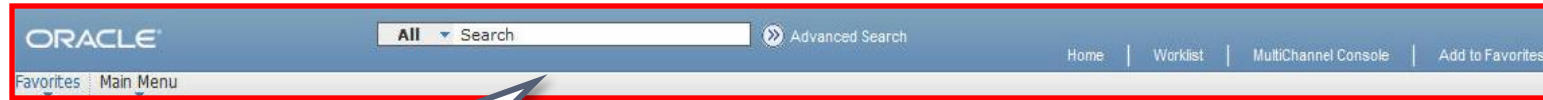

PeopleSoft 9.1

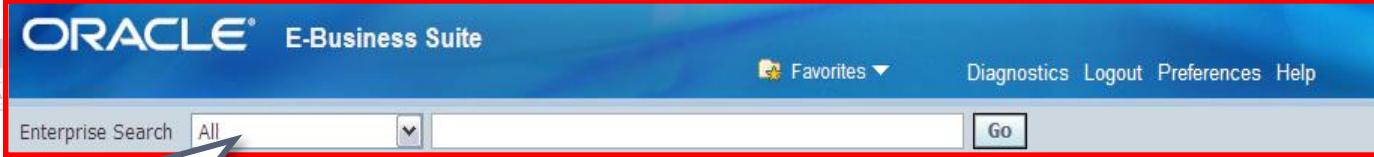

E-Business Suite 12.1.3



Fusion Applications

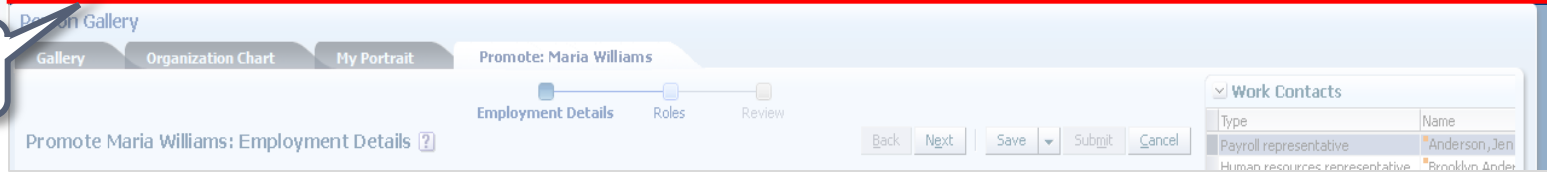

Common UX Design Patterns

Efficient Item Selection with Type-Ahead

New	Name	Site	Parent	Main Phone #	Status	Account Type	Account Team	Account Class	Fun
	FinanceOne Corporation	San Francisco	Foster Farms Chick	(425) 756-4757 x0	C	Customer	SADMIN	Customer	N
	AG Edwards & Sons, Inc	San Francisco		(415) 742-4500		Commercial	SADMIN	Customer	N
	Abu Nidal organization (Al	indfiasdsd					SADMIN		N
	Active Systems - Head Qu	HQ	Consulting Associa	(650) 755-7555		Customer	SADMIN	Customer	N
	Active Systems - SFO	San Francisco		(650) 555-1212		Customer	SADMIN	Customer	N
	Active Systems - San Fran	San Francisco, USA				Customer	SADMIN	Customer	N
	Albany County General Ho	Albany		(201) 874-2314	Active	Hospital	SADMIN	Customer	N
	All American Insurance Ag	Bay Area		(415) 555-1234		Partner	SADMIN	Customer	N
	Altman Capital Corporatio	HHQ				Commercial	SADMIN	Customer	N
	Alvarez	HQ-Distribution			Active	Retailer	SADMIN	Customer	N

View records 1 - 10 of 10

Common UX Design Patterns

Analytics Bring Insight and Action Together

The screenshot displays the Siebel 8.1 user interface. On the left, a window titled 'My Activities' contains a table with columns: New, Type, Description, Priority, and Activity. The first row is highlighted in yellow. On the right, a window titled 'My Analytics' displays a bar chart titled 'Service Request Trends' with a legend for Critical, High, Medium, and Low priority requests across five dates in 2009. A red box highlights the 'My Analytics' window, and a callout bubble points to the 'Siebel 8.1' text.

New	Type	Description	Priority	Activity
	Analyst	Customer Session		General
	Investment NA	Investment Objective	2-High	General
	Call - Inbound	Inbound call		General
	Call	Noticed that custom	3-Medium	General
	Deter_Serv_Provider	01 Determine Servic	1-ASAP	General
	Investment NA	Investment Objective	3-Medium	General
	Call - Inbound	Inbound call		General

Siebel 8.1

Service Request Trends
(Drill on chart for details)

- 1-Critical # of SRs
- 2-High # of SRs
- 3-Medium # of SRs
- 4-Low # of SRs

Date	1-Critical	2-High	3-Medium	4-Low
2009 / 01	3	2	2	1
2009 / 02	4	4	4	1
2009 / 03	1	1	4	1
2009 / 04	4	4	3	1
2009 / 05	5	4	1	1

Common UX Design Patterns

Detail on Demand: Information As Needed

+ Today Friday, August 24, 2012

Done Planned Unscheduled

Friday 8/24

08aa [Begin Radio Broadcasts](#)

09aa **Siebel 8.1**

10aa

11aa

Type: Tactic
Description: Begin Radio Broadcasts
Start Time: 8/24/2012 08:00 AA
End Time: 8/24/2012 09:30 AA
Meeting Location:
Comment:

8:25 - 8:55 ANDREW LAM

For Developers: Patterns Mean Productivity

Efficiency Through Built-In Usability

The screenshot shows the Oracle Fusion Applications interface for editing an invoice. The main content area is titled 'Edit Invoice: PO-INV3173'. It features a form for invoice details, a table for invoice lines, and summary sections for status, holds, and payments. A red box highlights the 'Applications panel' area, which includes the 'Invoice Header' form and the 'Lines' table. A callout points to the 'Applications table' within the 'Lines' section.

Applications panel

Applications table

* Number	* Type	* Amount	Number	Line	Schedule	Quantity	Unit Price	UC
1	Item	10.00	1000143	1	1	1	10	E
2	Item	10.00	1000143	2	1	1	10	Ea
3	Item	10.00	1000143	3	1	1	10	Ea
4	Item	10.00	1000144	1	1	1	10	Ea
5	Item	10.00	1000144	2	1	1	10	Ea
6	Item	10.00	1000144	3	1	1	10	Ea

Applications UI Shell

Learn More About Oracle Apps UX Online

- Workshops and developer events
- Oracle.com/UsableApps
- Blogs.oracle.com/VoX
- Blogs.oracle.com/UsableApps
- Twitter: @usableapps

ORACLE®